



MARTINOTTI
PREFABBRICATI

MARTINOTTI PREFABBRICATI s.r.l.

Strada Fossamana nr. 9 - 46100 Mantova
tel. +39.0376.340504 - fax +39.0376.340427
mail: prefabbricati@martinotti.it - www.martinotti.it



Certificato N.
IT06/0961

CE

Certificato N.
1381-CPR-196

SCHEDE TECNICHE ILLUSTRATIVE

settore di intervento:

STRUTTURE PER DEPURAZIONE



ELENCO SCHEDE :

D _ vista assonometrica

D1 _ parete tipo A

D2 _ parete tipo B

D3 _ parete tipo C

D4 _ pannelli con canalette

D5 _ esempi di sedimentatori

D6 _ esempi di pareti con passerella superiore

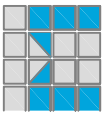

PLANIMETRIA IMPIANTO DI DEPURAZIONE : ESEMPIO



Gli impianti di depurazione richiedono l'esecuzione di un insieme articolato di manufatti. La Martinotti Prefabbricati è in grado di realizzare tutte le opere strutturali e civili.



VEDI PARTIC.

VEDI PARTIC.

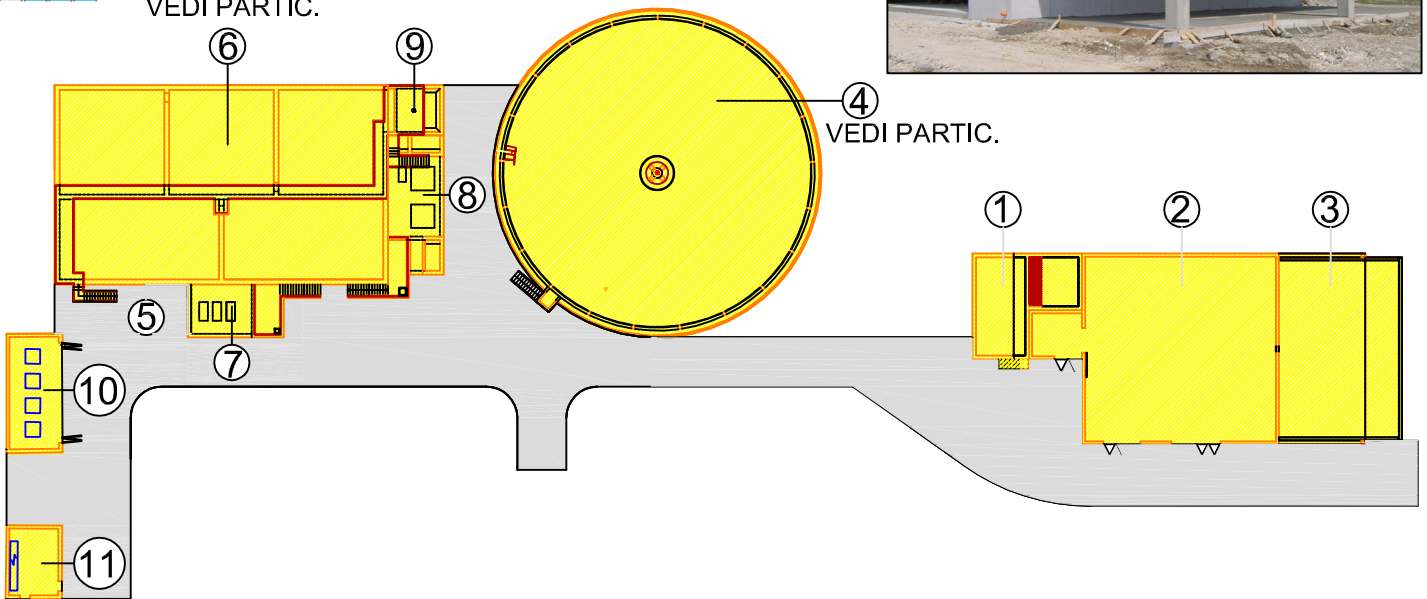

- 1 VASCA AERATA ACCUMULO FANGHI PRIMARI
- 2 DISIDRATAZIONE FANGHI
- 3 STOCCAGGIO FANGHI DISIDRATATI
- 4 SEDIMENTAZIONE BIOLOGICA
- 5 BILANCIAMENTO PRINCIPALE
- 6 OSSIDAZIONE A FANGHI ATTIVI
- 7 SOLLEVAMENTO ACQUE BILANCIATE
- 8 CENTRALE DI SOLLEVAMENTO
- 9 DEAREAZIONE
- 10 LOCALE SOFFIANTI
- 11 SALA QUADRI





PRODOTTI PREFABBRICATI DI CALCESTRUZZO: Elementi da parete

PARETI PER VASCHE



MARTINOTTI
PREFABBRICATI

mail:prefabbricati@martinotti.it - tel. +39.0376.340504



Caratteristiche dei Pannelli Prefabbricati :				Spessore	Larghezza	Altezza riempimento (battente massimo)		
				cm 28	mt 2,40	H. da 2,50 a 3,95 mt		
				cm 36	mt 2,00	H. da 4,00 a 4,60 mt		
Calcestruzzo					Acciaio ordinario			
Classe	RcK	Esposiz.	Consist.	ømax inerte (mm)	fcd (N/mm ²)	Tipo	f _y (N/mm ²)	f _t (N/mm ²)
C32/40	40	XA2	S4	25	18.81	B 450 C	450	540
Per caratteristiche di resistenza meccanica, resistenza al fuoco, parametri di isolamento acustico e durabilità si fa riferimento alle specifiche di progetto.								

PARTICOLARE ASSEMBLAGGIO PANNELLI PREFABBRICATI

GIUNTO DI COLLEGAMENTO IN OPERA

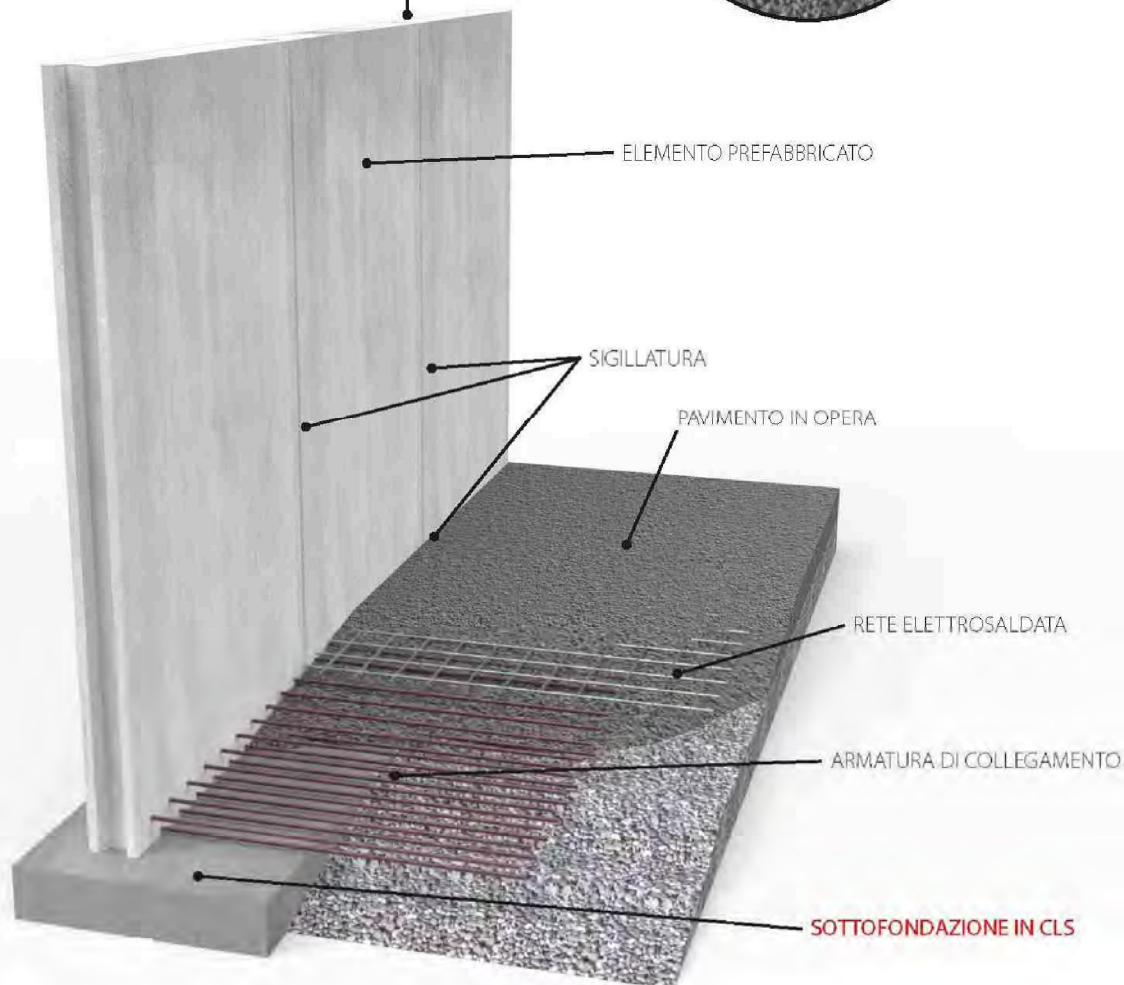
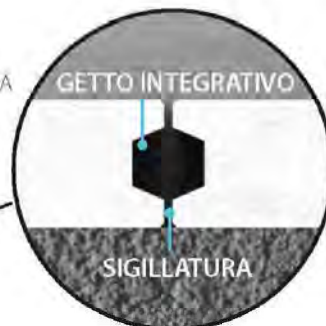

La proprietà di questo disegno è riservata a termine di legge



PRODOTTI PREFABBRICATI DI CALCESTRUZZO: Elementi da parete

PARETI PER VASCHE



MARTINOTTI
PREFABBRICATI

mail:prefabbricati@martinotti.it - tel. +39.0376.340504

PARETI TIPO A - spessore cm 28

Caratteristiche dei Pannelli Prefabbricati :				Spessore	Larghezza	Altezza riempimento (battente massimo)		
				cm 28	mt 2,40	H. da 2,50 a 3,95 mt		
Calcestruzzo					Acciaio ordinario			
Classe	RcK	Esposiz.	Consist.	ømax inerte (mm)	fcd (N/mm ²)	Tipo	f _y (N/mm ²)	f _t (N/mm ²)
C32/40	40	XA2	S4	25	18.81	B 450 C	450	540
Per caratteristiche di resistenza meccanica, resistenza al fuoco, parametri di isolamento acustico e durabilità si fa riferimento alle specifiche di progetto.								



SEZIONE PANNELLO LATERALE

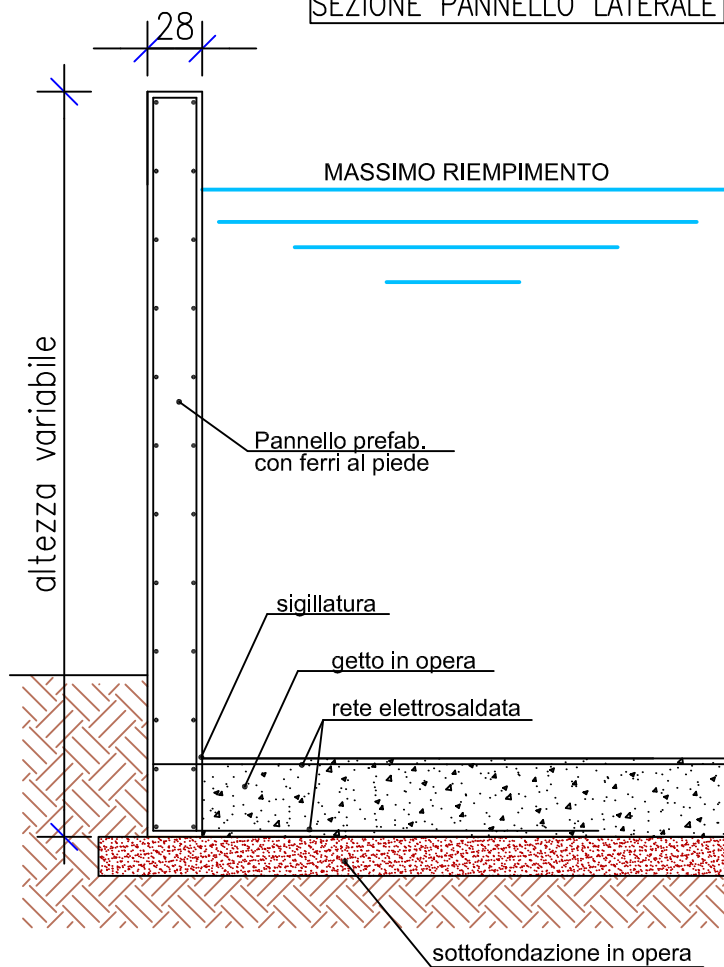

PUOI PROGETTARE FORME
RETTANGOLARI, OVALI, CIRCOLARI

PUOI CREARE PIU' SCOMPARTI

PUOI PENSARE LA VASCA FUORI TERRA

○ INTERRATA

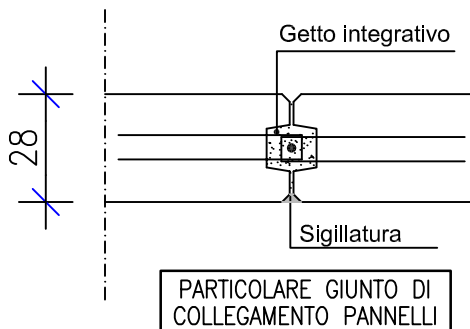
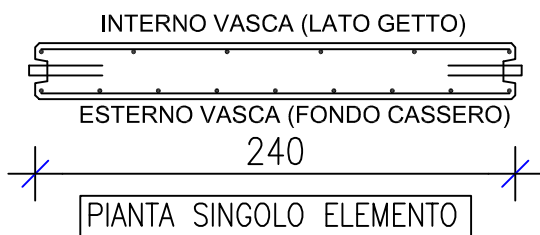



PRODOTTI PREFABBRICATI DI CALCESTRUZZO: Elementi da parete

PARETI PER VASCHE



MARTINOTTI
PREFABBRICATI

mail:prefabbricati@martinotti.it - tel. +39.0376.340504

PARETI TIPO B - spessore cm 36

Caratteristiche dei Pannelli Prefabbricati :				Spessore	Larghezza	Altezza riempimento (battente massimo)		
				cm 36	mt 2,00	H. da 4,00 a 4,60 mt		
Calcestruzzo					Acciaio ordinario			
Classe	RcK	Esposiz.	Consist.	ømax inerte (mm)	fcd (N/mm ²)	Tipo	f _y (N/mm ²)	f _t (N/mm ²)
C32/40	40	XA2	S4	25	18.81	B 450 C	450	540
Per caratteristiche di resistenza meccanica, resistenza al fuoco, parametri di isolamento acustico e durabilità si fa riferimento alle specifiche di progetto.								



SEZIONE PANNELLO LATERALE

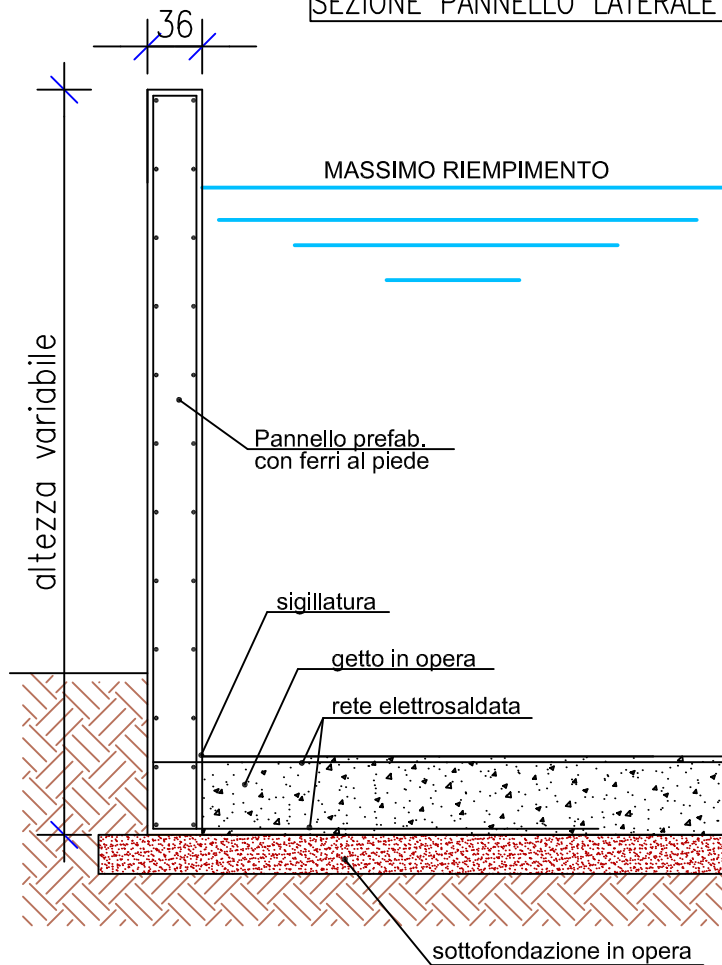

PUOI PROGETTARE FORME
RETTANGOLARI, OVALI, CIRCOLARI

PUOI CREARE PIU' SCOMPARTI

PUOI PENSARE LA VASCA FUORI TERRA

○ INTERRATA



INTERNO VASCA (LATO GETTO)

ESTERNO VASCA (FONDO CASSERO)

200

PIANTA SINGOLO ELEMENTO

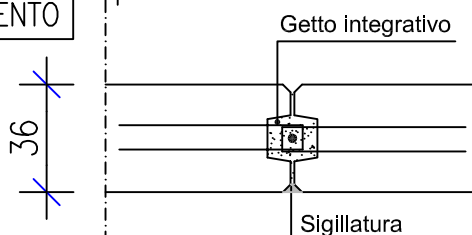

PARTICOLARE GIUNTO DI
COLLEGAMENTO PANNELLI



PRODOTTI PREFABBRICATI DI CALCESTRUZZO: Elementi da parete

PARETI PER VASCHE



MARTINOTTI PREFABBRICATI

mail:prefabbricati@martinotti.it - tel. +39.0376.340504



Certificato N. IT06/0961



Certificato N. 1381-CPR-196

PARETI TIPO C - spessore variabile

Caratteristiche dei Pannelli Prefabbricati :				Spessore cm 60-28	Larghezza mt 2,00	Altezza riempimento (battente massimo) H. 5,40 mt		
Calcestruzzo					Acciaio ordinario			
Classe	RcK	Esposiz.	Consist.	ømax inerte (mm)	fcd (N/mmq)	Tipo	fy (N/mmq)	ft (N/mmq)
C32/40	40	XA2	S4	25	18.81	B 450 C	450	540
Per caratteristiche di resistenza meccanica, resistenza al fuoco, parametri di isolamento acustico e durabilità si fa riferimento alle specifiche di progetto.								

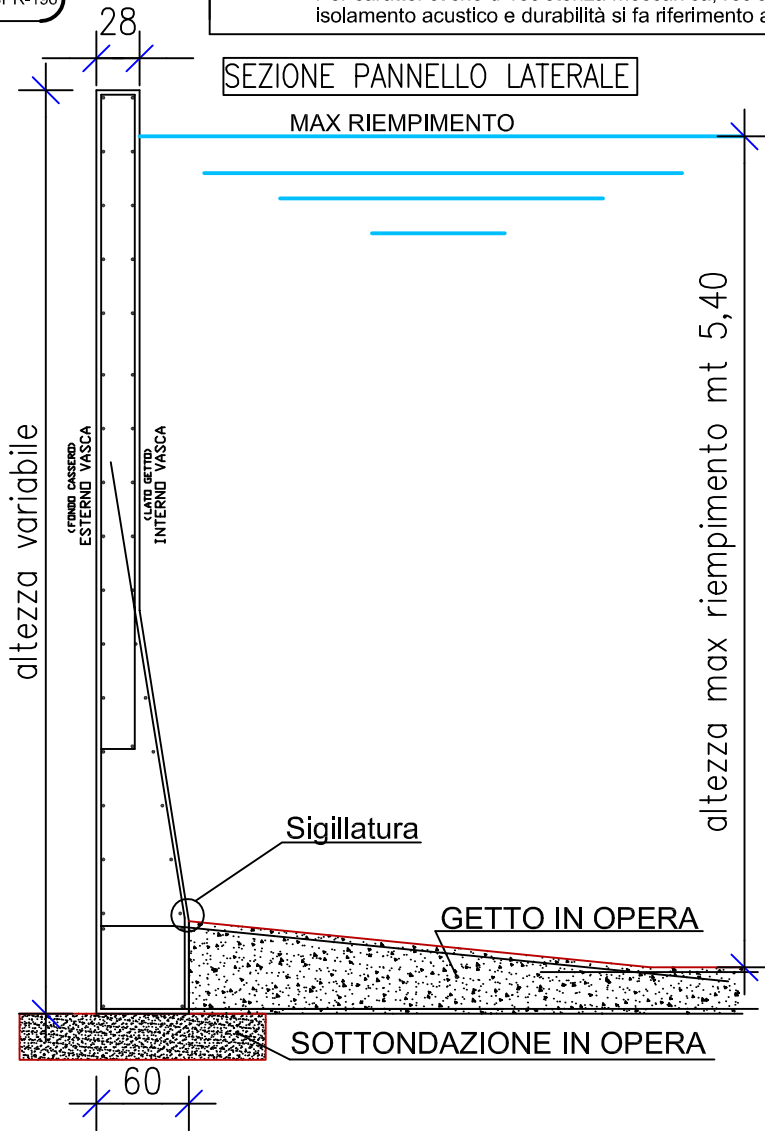

PARTICOLARE GIUNTO DI COLLEGAMENTO PANNELLI

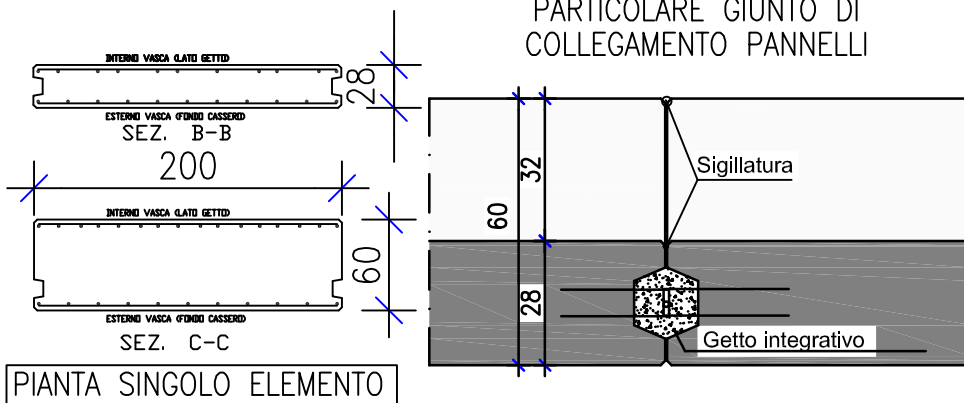



STRUTTURE PER DEPURAZIONE: APPLICAZIONI



MARTINOTTI
PREFABBRICATI

mail:prefabbricati@martinotti.it - tel. +39.0376.340504

ESEMPI DI PANNELLI CON SFIORO E CANALETTA INTERNA O ESTERNA



TIPO 1

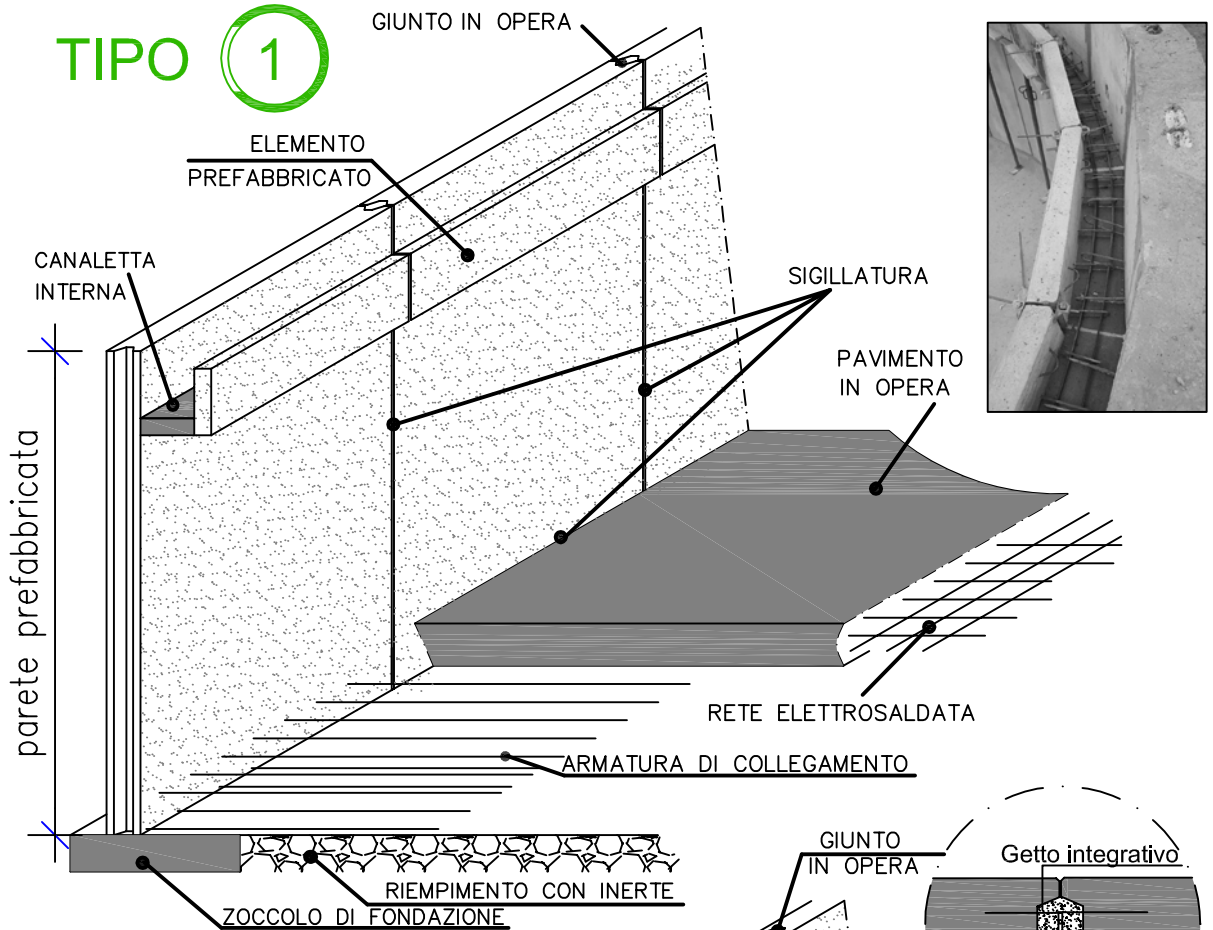

TIPO 2

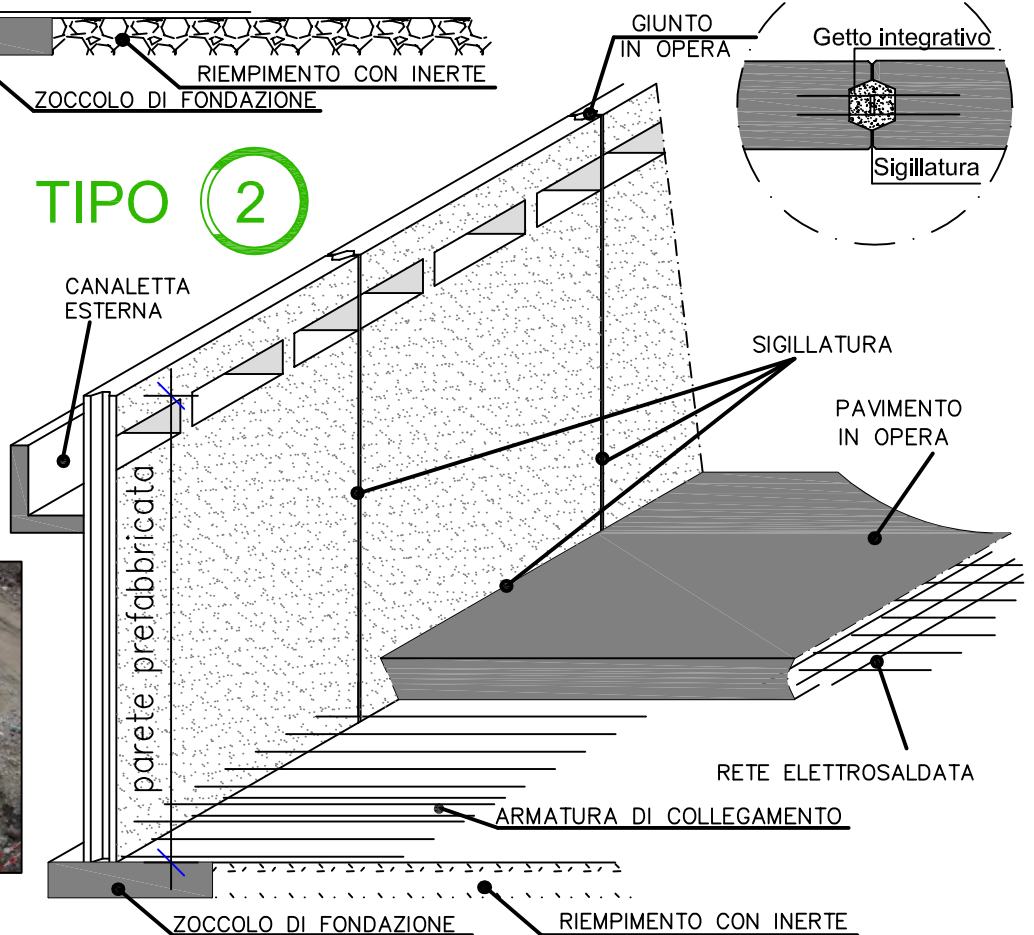



STRUTTURE PER DEPURAZIONE: APPLICAZIONI



MARTINOTTI
PREFABBRICATI

mail:prefabbricati@martinotti.it - tel. +39.0376.340504



Certificato N.
IT06/0961



Certificato N.
1381-CPR-196

ESEMPIO DI SEDIMENTATORE

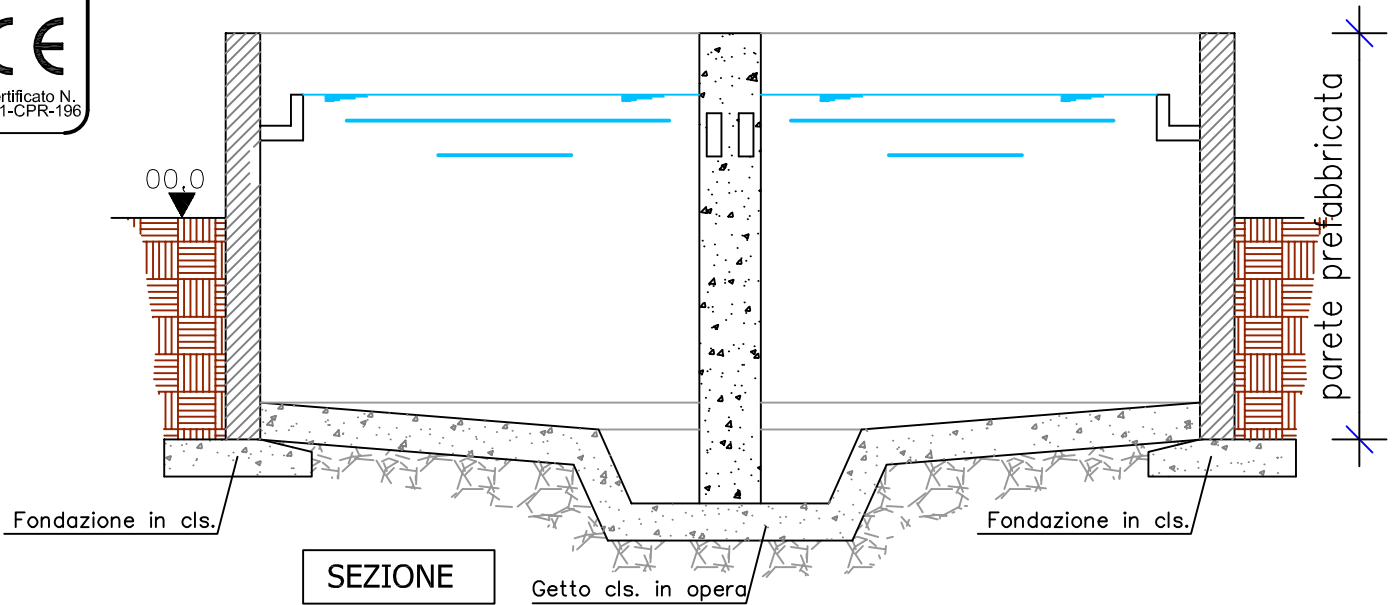



STRUTTURE PER DEPURAZIONE: APPLICAZIONI



ESEMPI DI PANNELLI CON PASSERELLA SUPERIORE

